

SECTION 16. HAZING

1. The relationship of the old cadet to the new cadet shall be one of service and helpfulness, so that the new cadet will become imbued with the spirit and traditions of the Staunton Military Academy. The character and development of the new cadet is in great measure dependent on the spirit displayed by the old cadet, and the ultimate success of the new cadet, his attitude and his achievement, will be largely determined by the training he received from the old cadets during his first year of residence at Staunton.

2. Hazing is an unauthorized assumption of authority by one cadet over another whereby the latter shall or may suffer physical punishment, indignity, oppression, or the deprivation of a right or privilege or advantage to which he is legally entitled. No new cadet shall be required to perform menial labor or personal services for an old cadet.

3. Hazing in any form is prohibited at Staunton.

4. No cadet shall order another to report to any room for correction, instruction, bracing, or for any purpose whatever, except:

a. A cadet company commander may order a cadet or a group of cadets to report to his room and in his presence for the transaction of official company business. This will not conflict with Call to Quarters (C.Q.).

b. The senior cadet officer of a duly constituted Honor Committee may order cadets before his committee.

5. First year cadets will not be detailed nor will they be permitted to perform any personal service for an old cadet such as opening and closing windows or doors of rooms, purchasing articles, sweeping rooms, handling beds or bedding, cleaning equipment, or handling laundry.

6. New cadet rules published by the Commandant are not considered to be hazing. No abuse of these rules will be permitted.



SECTION 17. HONOR COMPANY

1. **General:** At the close of each month an Honor Company for the month is selected from the lettered companies and the Band. Being selected as the Honor Company is a singular honor. It is evidence that cadets, in cooperation with their comrades and their company, have maintained the highest standards in the Corps in connection with practically all of their activities as cadets.

2. **Privileges of the Honor Company:** The Honor Company is granted certain privileges. The Honor Company may be dismissed early from drill. It may be given leave on Friday afternoon and is excused retreat and personal inspection on that day. The Honor Company carries a distinctive guidon in addition to its regular guidon to signify the company's achievement in being awarded this honor. At the close of each year an Honor Company of the year is selected and awarded a streamer to be permanently attached to the company guidon. Cadets assigned to Honor Company at that time may wear the distinctive Honor Company badge on their "C" uniform. The company designated Honor Company for a year retains the privileges during the first month of the next school year.

3. Company standing in the monthly Honor Company competition is determined by the SAI based on each company's performance in the following fields of activity:

a. **Parade Rating**—Maximum value 20 points. The SAI or Military Duty Officer assisted by designated cadet officers from the Cadet Corps Headquarters rate each company's overall performance at all Sunday and special parades.

b. **March-In Rating**—Maximum value 15 points. Cadet officers designated on orders published by the Cadet Corps Commander rate the performance of each company at each mess hall march-in, except optional messes, and submit the results to the SAI.

c. **Guard Rating**—Maximum value 10 points. The Military Duty Officer rates each guard on several factors during its entire tour of duty and submits the rating to the SAI. Rating factors are shown on Guard Performance Rating Form.

d. **Commandant's Rating**—Maximum value 20 points. This rating is based on the conduct and appearance of students in barracks and the condition of barracks rooms as determined by inspections conducted by the Commandant or reported to him by barracks faculty officers.

e. **SAI Rating**—Maximum value 25 points. The SAI or members of the Military Department will inspect during the month for typical deficiencies that include:

- (1) Military Courtesy
- (2) Unshaven Appearance
- (3) Unbuttoned Uniform
- (4) Uniform worn improperly (Ex: no headgear, hat on back of head, unauthorized type shoes, white socks not authorized by medical excuse, short trousers, uniform items in need of mending).
- (5) Lost Weapons
- (6) Other items selected at discretion of SAI.

The SAI's rating is devised to seriously penalize those companies whose cadets fail to achieve the established military standards.

f. Senior Captain's Rating is based on his observations. 15 points are allocated to this cadet.

g. Other Ratings: Academic achievements as well as intramural standing and results of various other school sponsored activities are included in Honor Company Ratings for the month of their completion. Up to 15 points may be authorized.

SECTION 18. HOWIE RIFLE HONOR SOCIETY

1. The Howie Rifles were established by General Order 31, Staunton Military Academy, 18 March 1945, to perpetuate the ideals, leadership, and courage exemplified by Major Thomas Dry Howie, 116th Infantry, 29th Division, a former instructor at Staunton Military Academy who was killed on the field of battle on 17 July 1946 while leading his battalion in the capture of the key position of Saint Lo, France prior to the breakout of the Normandy beachhead.

2. **Membership**—Selection is made by the SAI.

a. Cadets are selected for membership in the Howie Rifles on the basis of excellence in all phases of cadet activity. Membership is normally restricted to cadets who have served a minimum of one year in the Corps at the senior school.

b. Prior to the beginning of each school year, the SAI considers all cadets who have completed at least one semester service in the Corps. From the records of the previous year, he assigns each cadet a numerical rating based on conduct, military training, military aptitude, academics and leadership.

c. The SAI then arranges the cadets considered numerically with relation to their rating and determines the rating of the 70th cadet from the top. His rating is considered the cut off score. All cadets with this rating or higher are then considered for membership in the Howie Rifles. This list is then reviewed by the Commandant, Headmaster, and Superintendent to determine if the past record of any cadet on the list should disqualify him for membership.

d. The cadets selected as members of the Howie Rifles are announced in a Special Order published at the beginning of the school year.

3. **Organization:**

a. The Cadet Corps Commander is the Commander of the Howie Rifles. He selects senior drill masters and guidon bearers.

b. The Honor Society is divided into two groups; drill team members and honorary members. Members of the drill team are selected from the rifles companies. Honorary members are selected from the Brigade Band and the Headquarters Company.

c. The drill team is organized as directed by the SAI. Honorary members are not assigned to any particular unit and do not participate in the drill exhibitions.

4. **Insignia:** Members of the Howie Rifles are authorized to wear the Howie Rifles shoulder patch, (a white bayonet on a blue shield trimmed in red and with the words Howie Rifles in white) on the right shoulder of the "C" coat.

5. **Activities:**

a. The Howie Rifle Drill team practices its special drills and manual during the fall and spring on dates designated by the SAI. Cadets who fail to attend drill may be dropped from the rolls and lose their privileges and honors accorded to the society.

b. A cadet who is reduced in rank for misconduct or inefficiency may be dropped from the rolls and lose all privileges and honors accorded the society.

c. The Howie Rifles with the Brigade Band and Color Guard represent the Corps at numerous civic and military events during the school year.



SECTION 19. INFIRMARY REGULATIONS

1. Sick call shall be at 1700 hours Monday thru Thursday inclusive, at 1630 hours on Friday, and at 0930 hours on Sundays. There is no scheduled Sick Call on Saturday. At Sick Call cadets wishing to see the school doctor will report to the Infirmary Office.

2. When necessary to report to the Infirmary at times other than sick call, a cadet will obtain a permit from the Commandant of Cadets or his representative. This permit will be presented at the Infirmary and in case the cadet is not detained at the Infirmary, the slip will be returned to the Commandant by the cadet himself; if the cadet remains in the Infirmary, the slip will be returned to the Commandant by a member of the guard. A cadet who is suddenly and severely taken ill at any time will secure the assistance of a faculty officer at once; if at night, he should send a cadet to inform a resident faculty officer.

3. Cadets reporting to Sick Call will wear the uniform prescribed that day for other regular formations.

4. Cadets in the Infirmary must remain in their own infirmary rooms except when going to and from the wash room.

5. There shall be no visiting by cadets from one room to another, and no congregating in the wash room.

6. Cadets will not be allowed on the porches except by special permission of the school nurse.

7. Smoking in the Infirmary is not permitted.

8. No confinement to barracks rooms for illness shall be given except by the school doctor.

9. A cadet excused military duties is excused from drill and guard duty. At all formations of the Corps he will form with the medical detachment. Thereafter he will observe "Call to Quarters" or report to the Study Hall or other designated location unless other duty is authorized or ordered. (See paragraph 9, Section 33 for addition information.)

10. Cadets are not permitted to visit other cadets in the Infirmary.

SECRET - SECURITY INFORMATION

1. The purpose of this document is to provide a comprehensive overview of the current status of the project and to identify the key areas of concern. It is intended for the use of senior management and other stakeholders who are responsible for the overall direction and control of the project.

2. The project has made significant progress since the last report, with most of the major milestones being achieved on time. However, there are several areas where the project is currently behind schedule, and these need to be addressed as a matter of priority.

3. The primary areas of concern are the delays in the procurement of key components, the lack of progress in the development of the software, and the limited resources available to support the project. These issues are being actively managed, but it is essential that the project team continues to work closely with the relevant departments to ensure that the project remains on track.

4. In order to address these issues, the following actions are being taken: (a) the procurement process is being expedited, (b) the software development team is being restructured to improve efficiency, and (c) additional resources are being allocated to the project to ensure that the critical path activities are completed on time.

5. It is expected that the project will be completed by the end of the year, and that the results will be in line with the original objectives. However, it is important to remain vigilant and to continue to monitor the project closely to ensure that any further issues are identified and resolved as quickly as possible.

SECTION 20. INSPECTIONS

1. General: Regularly scheduled inspections of personnel, quarters, arms, clothing, and equipment are an important part of a cadet's military training. Cadets are expected to keep their person, their living quarters, their arms, clothing, and equipment in proper condition. Inspections serve to keep a cadet, as well as his superiors, appraised of the success of his efforts to do so.

2. Inspection of Quarters:

a. Press arrangement: Authorized articles will be placed in presses in accordance with Figure 3 for most presses and Figures 4 and 5 for old type presses and dressers (North Barracks). No other articles will be visible, except that, in case of a prolonged absence, the press will be draped with a sheet to protect its contents.

b. Clothing and equipment will be clean and orderly, folded and pressed as appropriate. Material on shelves will be placed flush with the edge of the shelf, rolled edges forward. Shoes in press will be laced, tied, and polished. Brass and black boxes will be polished. Uniforms will be buttoned.

c. A memorandum will be published yearly on marking of clothing and equipment. All items of clothing, books, and other equipment belonging to a cadet will be marked with the cadet's laundry number.

d. Beds will be made at all times except on Friday when bed linen will be changed. Beds will be made prior to general leave on Friday. (See Figure 2.)

e. Beds, presses, desks, and dressers will be tagged with the owner's name.

f. Blankets will be free of holes.

g. All beds will have a pillow and as topmost, an SMA blanket.

3. Arrangement of Press:

a. Numbers which follow correspond with Figure 3.

1. Sweat clothing, knit cap and athletic shoes: Shoes will be clean with laces tucked in tops.

2. White ducks and sweaters: All folded same width, school sweater on top.

3. Shoe polishing equipment: Cloth will be clean and neatly wrapped around the brush.

4. Neckties: Folded twice.

5. Handkerchiefs: Folded square, twice each way.

6. White belting and brass: Folded twice with extra brass polished and on top of belting.

7. Socks: Each pair firmly rolled and enveloped in top of one sock, open ends and white socks rearward, socks will not be stacked on top of each other.

8. Gloves: White arranged the same as socks, with greys rearward, neither folded nor rolled.

9. Pillow Cases: Folded, with 6" front.

10. White shirts: Folded with 10" front, buttons concealed.

BED MAKING

EXTRA BLANKET BOTTOM ENDS

HOSPITAL CORNERED, "S" FOLDED,

WITH OVERLAPPING SIDES TUCKED

UNDER

PILLOW TUCKED

FOLD
6" to 8"
WIDE

BLANKET TIGHT

NAMETAG

← 18-25" →

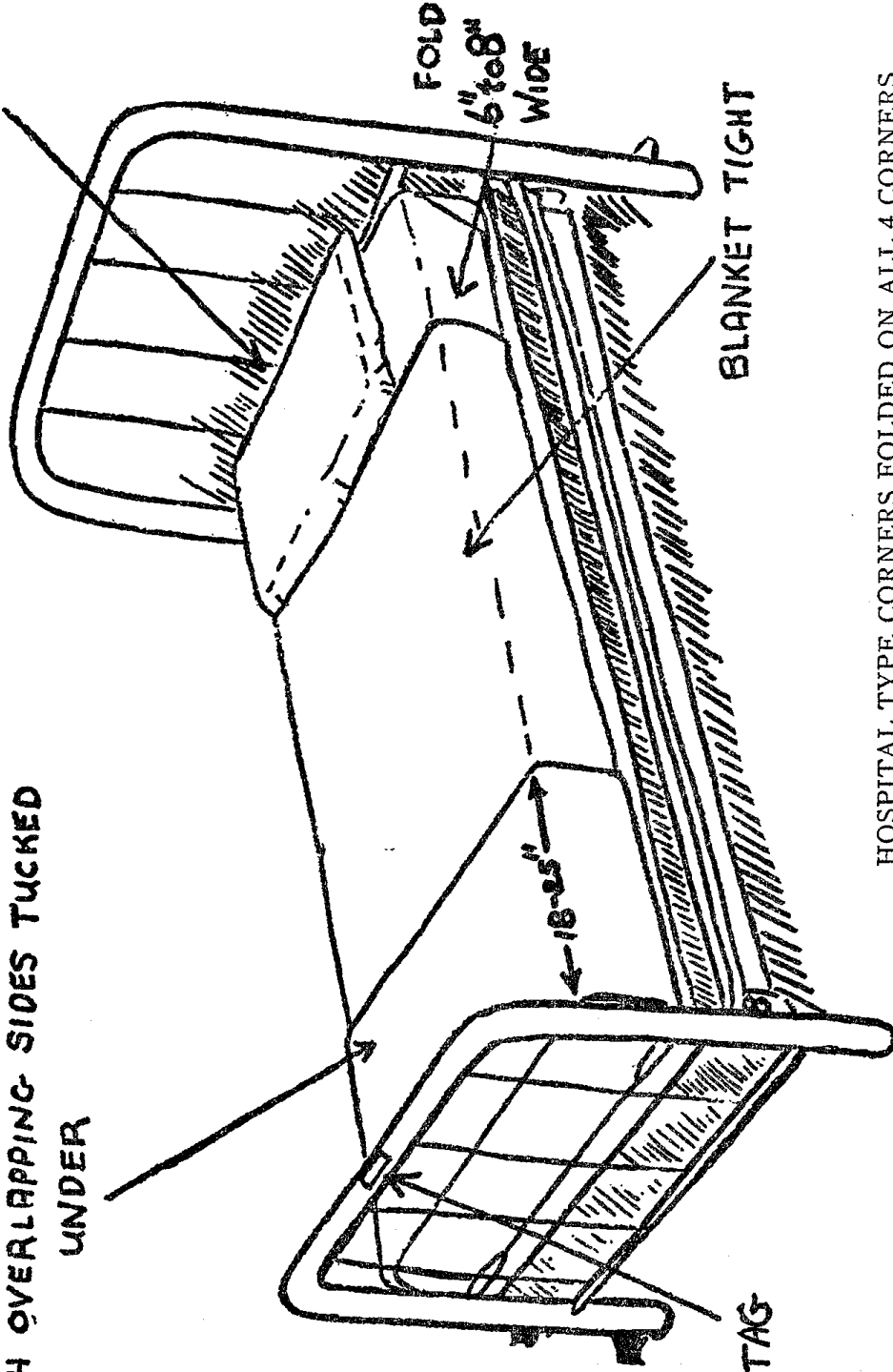

HOSPITAL TYPE CORNERS FOLDED ON ALL 4 CORNERS

Figure 2

ARRANGEMENT OF NEW-TYPE PRESS

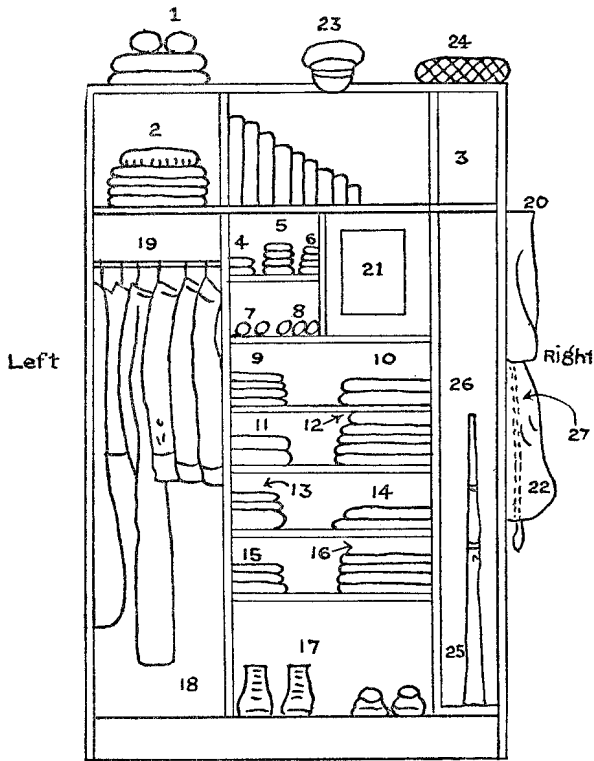

Figure 3

NOTE: All articles are to be exactly reversed on a "right hand press."
See paragraph 3 for explanation of numbers.

11. Sheets: Folded with 6" front.
12. Grey shirts: Same as white shirts.
13. Underclothing: Undershirts uppermost, all folded with 6" front.
14. Pajamas: Folded, with 10" front.
15. Hand towels and Wash Clothes (Clean): Folded with 6" front, wash cloths on top, folded twice.
16. Bath Towels: Folded with 10" front.
17. Shoes: Black only, limit three pairs, cleaned, polished, and laced, laces tucked in at top; front row to be similar in type, if possible (if not, high tops will be on the right). Slippers will be placed at right, behind shoes, all toes point outward. Where necessary, shoes on back row will be flat on floor, with heels of front row on toes of rear row so that none protrude beyond front edge.
18. Overshoes and shower clogs: Overshoes are on left.

19. Hanging Clothes: Buttoned, hanger hooks rearward, buttoned and/or shorter garments nearest the rifle, limited per hanger to:
 - “C” Coat
 - “D” Coat
 - Overcoat
 - Raincoat
 - Bathrobe
 - “Straights” will be hung under the “C” coats.
 - Athletic sweater
 - Buttoned shirt
20. Towels and wash cloths in use.
21. Lock Box: Toilet and miscellaneous articles will be neatly arranged within, the former toward the front.
22. Laundry Bag.
23. Caps: Service (visored) with garrison underneath.
24. Extra blanket or comforter.
25. Rifle and cleaning rod: Sights toward front.
26. Black Box.
27. Sword: Suspended under laundry bag.

Arrangement of Old-Type (North Barracks) Press and Dresser:

- a. Numbers which follow correspond with Figures 4 and 5.
 1. Sweat clothing and athletic shoes: Shoes will be clean with laces tucked in at top; sweat clothes folded same width.
 2. White Ducks and Sweater: All folded same with school sweater only on top.
 3. Shoe Polishing Equipment: Displayed in neatest possible way.
 4. Neckties: Folded twice.
 5. Handkerchiefs: Folded square, twice each way.
 6. White Belts and extra Brass: Folded twice with extra brass polished and on top of belting.
 7. Socks: Each pair firmly rolled and enveloped in top of one sock, open ends and white socks rearward. Socks will not be stacked on top of each other.
 8. Gloves: Whites arranged the same as socks with greys rearward neither folded nor rolled.
 9. Pillow cases: Folded with 6” front.

ARRANGEMENT OF OLD-TYPE PRESS

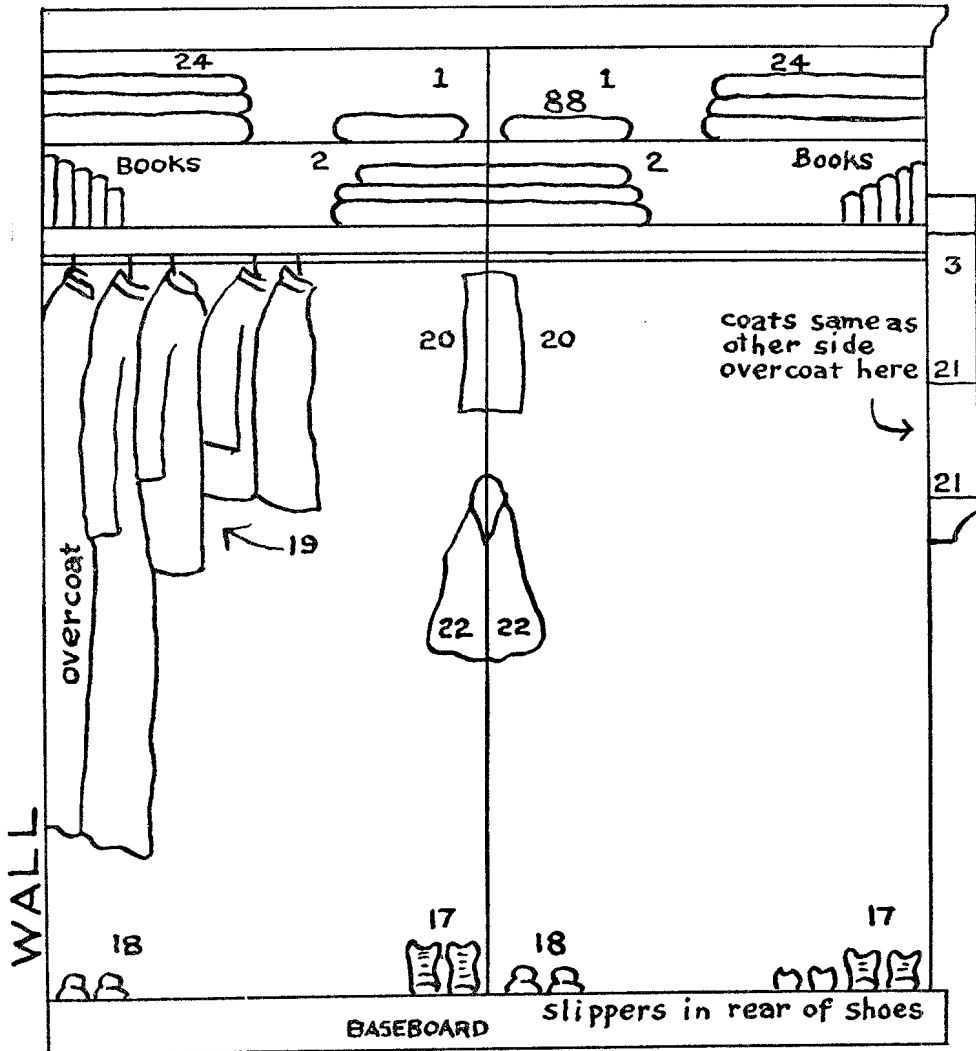

Figure 4

See paragraph 4 for explanation of numbers.

10. White Shirts: Folded with 10" front, buttons concealed.
11. Sheets: Folded with 6" front.
12. Grey Shirts: Same as white shirts.
13. Underclothing: Undershirts uppermost, all folded with 6" front.
14. Pajamas: Folded with 10" front.
15. Hand Towels and/or wash cloths: Folded with 6" front, wash cloths on top folded twice.

16. Bath Towels: Folded with 10" front.

17. Shoes: Black only, limit 3 pairs, polished, and laced, laces turned in at top; front row to be similar in type if possible (If not high-tops will be placed on the right). Slippers will be placed at right behind shoes. No shoes will protrude over edge of press; when necessary shoes in back row will be flat on the floor.

18. Overshoes and Shower Clogs: Overshoes on left at front of press.

ARRANGEMENT OF DRESSER AND RIFLE RACK

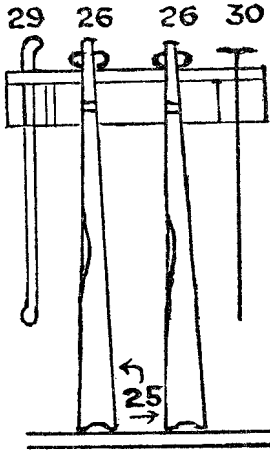

DRESSER CUT
AWAY TO SHOW
INSIDE

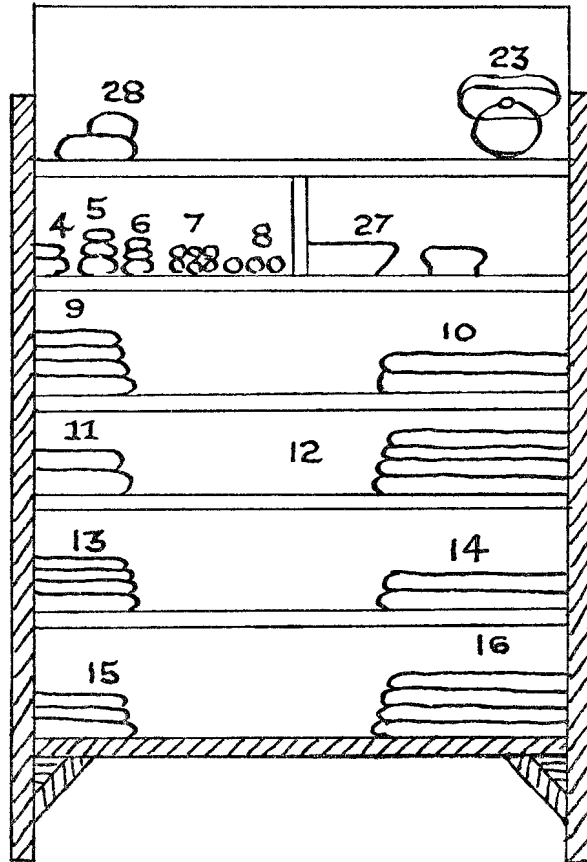

Figure 5

See paragraph 4 for explanation of numbers.

19. Hanging Clothes: Buttoned and hanger hooks facing wall. Clothes will be arranged in the following order with the bathrobe, athletic sweater and buttoned shirt at far ends.

“C” Coat

“D” Coat

Overcoat

Raincoat

Bathrobe

Athletic sweater

Buttoned shirt

“Straights” will be hung under the “C” Coats.

20. Towels and Wash Cloths in use.

21. Medicine Cabinet: For storage of soap, etc.

22. Laundry bag.

23. Caps: Service (visored) with overseas underneath will be placed to extreme right of dresser.

24. Extra blanket will be placed in top of press away from center.

25. Rifle: Placed in rifle rack, sights forward (away from wall).

26. Black Box: Placed behind barrel of rifle.

27. Space for cadet's personal belonging, Officer's wrap, etc.

28. Sword: Placed to left of rifle.

29. Cleaning Rod: Placed to right of rifle.

Inspection in ranks will be conducted in accordance with current US Army procedures.



SECTION 21. LAUNDRY

1. Each cadet will have two laundry bags.
2. Each cadet will be given a laundry number when he first reports to the Academy, and he will retain this number during his entire stay. All uniforms and equipment must be marked with this number.
3. Laundry slips will be furnished cadets. These slips will be filled out and placed in the bag with the soiled laundry. Each laundry slip contains a column showing the number of items of laundry which each cadet is allowed each week under his tuition charge. All items per week in excess of the allowance will be charged to the cadet as extras.
4. Laundry formations will normally be held Friday morning at reveille.
5. A cadet who receives the wrong laundry or any articles belonging to another cadet will return it at once to the laundry, reporting his action verbally to the Commandant. A cadet who upon checking his laundry finds articles which are damaged or missing, will fill in a claim slip and submit it to the Superintendent of the Laundry. If the claim is not settled satisfactorily to him, the cadet will report the facts verbally or in writing to the Business Manager.
6. No cadet will have soiled clothing taken to the laundry or picked up from that establishment by another cadet.
7. Special care should be taken to insure that dry cleaning is not sent to the SMA laundry.



SECTION 22. LIMITS

1. The following places on the grounds of the Academy are Off Limits to cadets :

- a. The Mess Hall, except at meals.
- b. The kitchen, cellar, pantry, and store rooms of the Mess Hall.
- c. Classrooms, laboratories and study halls, except at recitations or upon official business.
- d. Boiler rooms and coal-supply areas.
- e. Store rooms, attics and roofs, trunk rooms, except when accompanied by a faculty officer.
- f. Carpenter, plumbing and paint shops.
- g. The laundry, except when on official business.
- h. The Infirmary, except when on official business.
- i. The quarters of faculty officers in their absence, or except for official business or social functions when they are in residence.
- j. The swimming pool, except when officially opened and **when there is a faculty supervisor present.**
- k. The varsity athletic teams' dressing rooms, unless a member of the squad or on official business.
- l. Localities and streets that are designated Off Limits in general orders.

2. The following places in the City of Staunton and vicinity are Off Limits, except as noted :

- a. Mary Baldwin College and Stuart Hall, except for social calls or by invitation to social activities.
- b. The area both West of Green Street and South of Beverley Street.
- c. All farmlands and all private or "posted" fields or woodlands are Off Limits at all times, except by invitation of the owner in each case.
- d. The rock quarry and caves.
- e. All pool and billiard halls.

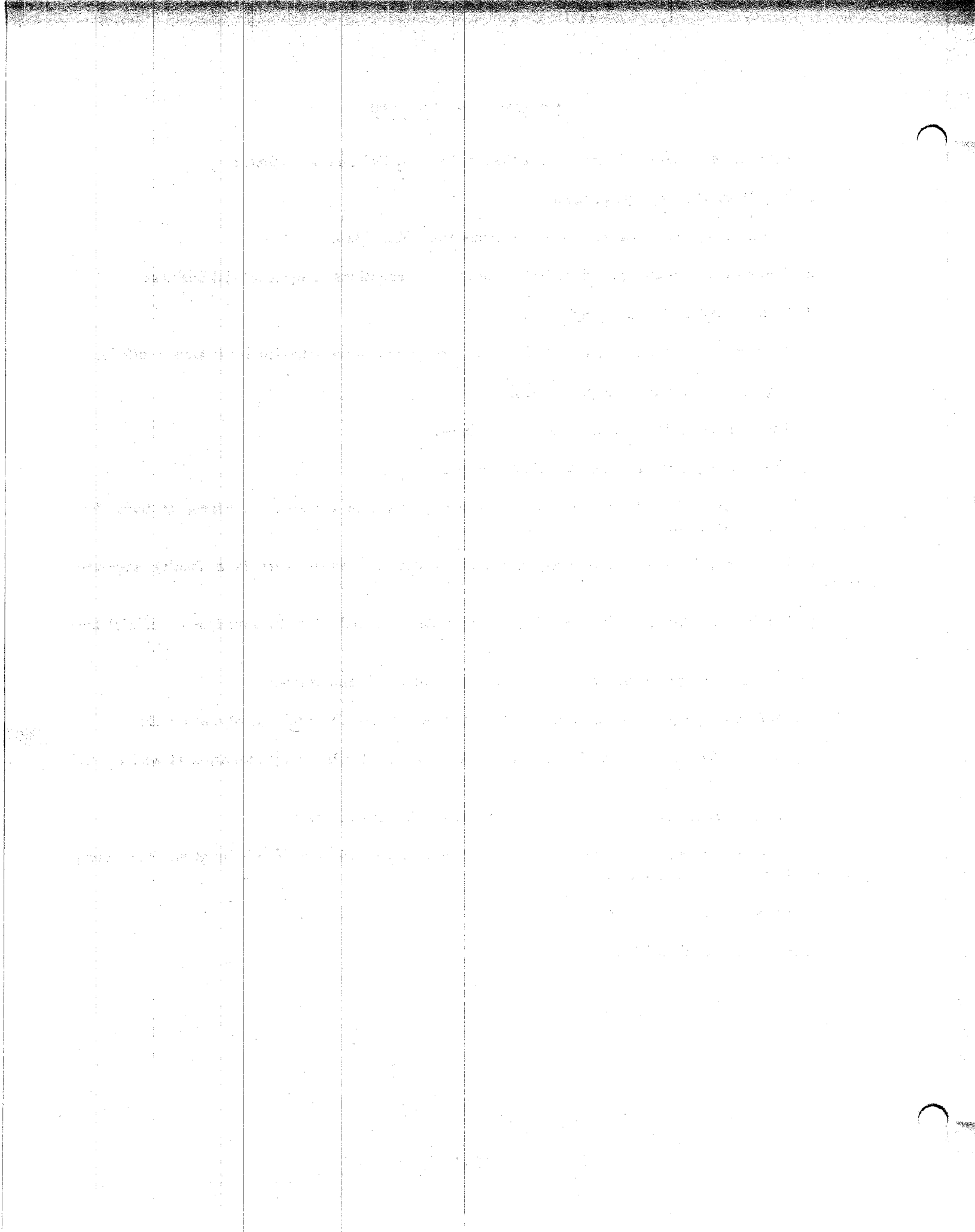

SECTION 23. MESS HALL REGULATIONS

1. The Mess Officer is responsible for the care and operation of the kitchen and dining room.

2. The Commandant of Cadets, assisted by the Mess Officer and other faculty will be responsible for the cadet organization, appointment of table commandants, seat assignments, and discipline in the Mess Hall.

3. Table commandants are charged with the maintenance of good order, particularly during announcements, march-in and march-out periods, and with the supervision of table manners.

4. Cadet table commandants who fail to correct and report violations of Mess Hall Regulations will be themselves reported for such failure by any faculty officer present.

5. No cadet may be absent from any meal without authority; all cadets are required to march to meals, except the following: the Officer of the Day, officers and noncommissioned officers of guard, the bugler of the guard and orderlies and those "excused marching" by the school Doctor.

6. Marching in and out of the Mess Hall will be at attention.

a. Upon entering, each cadet will move directly and rapidly as possible to his own place and will stand at attention behind his chair until the command "Rest" is given. The Corps Commander will designate those companies to move directly into the cafeteria line. Cadets in line are not to talk until "Rest" has been given.

b. Cadets will be designated for each table to insure that it is cleaned up prior to the second sitting.

7. The wasting of food, taking food or equipment from tables or out of the Mess Hall or interfering in any way with the food of others is prohibited.

8. Table commandants will report all damages of mess property that come to their attention, together with circumstances and names of those responsible to the Commandant.

9. Cadets on leave or pass who desire to eat in the Mess Hall **must attend mess formation and march into the Mess Hall with their company.**



SECTION 24. ORGANIZATION OF THE CORPS

1. **General:** The S.M.A. Corps of Cadets is composed of a Brigade of Infantry consisting of:
Headquarters and Headquarters Company

Band Company

Five lettered companies A-F

A Junior School Company (G)

2. **The Brigade:** At the Brigade level is the Brigade Commander, who at SMA may also be addressed as the First or Senior Captain. He is the highest ranking cadet and in overall command of the Corps. He may be assisted by an Executive Officer, an Adjutant (S1), a Training Officer (S3), an Intelligence Officer (S2), and a Supply Officer (S4).

3. An organizational chart is shown as Figure 6.

4. **The Companies:**

- a. Each lettered company is composed of two platoons of three or four squads each. The company is normally commanded by a captain, and the platoons by lieutenants. As a rule each platoon will have the following noncommissioned rank:

Platoon Sergeant—Sergeant First Class

Squad Leader—Staff Sergeant

Ass't Squad Leader—Sergeant or Corporal

In addition to the ranks enumerated above, each company will have as a senior NCO a First Sergeant and a Guidon Bearer whose grade will be either Corporal or Sergeant.

- b. As a member of a company, cadets will be directly concerned with their Company Commander, 1st Sergeant, Platoon Leader, and Platoon Sergeant, and Squad Leader. Cadets should know these Cadet Officers and noncoms as soon as possible. A word of caution: Learn the proper channels. The Cadet Officers and Noncoms will explain them. For example, if a cadet should want to discuss a problem with his Company Commander, it is considered the courteous thing to see the Platoon Leader first (since he may know the answer) and get permission from him to talk to the Company Commander.

- c. The Cadet Officers and Noncoms are not bent on abusing cadets or making "life hard". It is their responsibility to see that cadets "toe the line". Cooperation with Cadet Officers and Noncoms will make life pleasant for all concerned.

- d. Cadets will find that the life at SMA will be greatly tied to the company. To a large extent cadets will be quartered together; will eat together and engage in sports and games together. No company is any better than its weakest member. Join the spirit of cooperation and common effort for achievement as a member of the unit. Work for the Company, take pride in the Company, help make it the best Company on the Hill.

- e. Each Company has assigned to it a member of the Military Department as a Tactical Officer. His primary duty is to instruct and supervise the Company and its members in the performance of duty. He is available to cadets, however, to discuss any problems.

5. **The Band:** The Brigade Band is organized as a company and functions as such in administrative matters. Its organization is similar to that of a lettered company.

6. **Headquarters Company:** The Headquarters Company is composed of a Company Headquarters Detachment and three other detachments, the Ordnance and Medical Detachments, and the Color Guard. The Ordnance Detachment assists in the operation of the Armory, erection of Public Address set at drill assemblies, etc. The Medical Detachment assists in the operation of the Infirmary. The Color Guard assists in arranging for training aids to be at proper place at the proper time and maintains the training aids room. A fourth unit, the Day Student Platoon, may be included in the company. When used, this platoon acts as the control unit for all day students.

ORGANIZATION OF CORPS OF CADETS

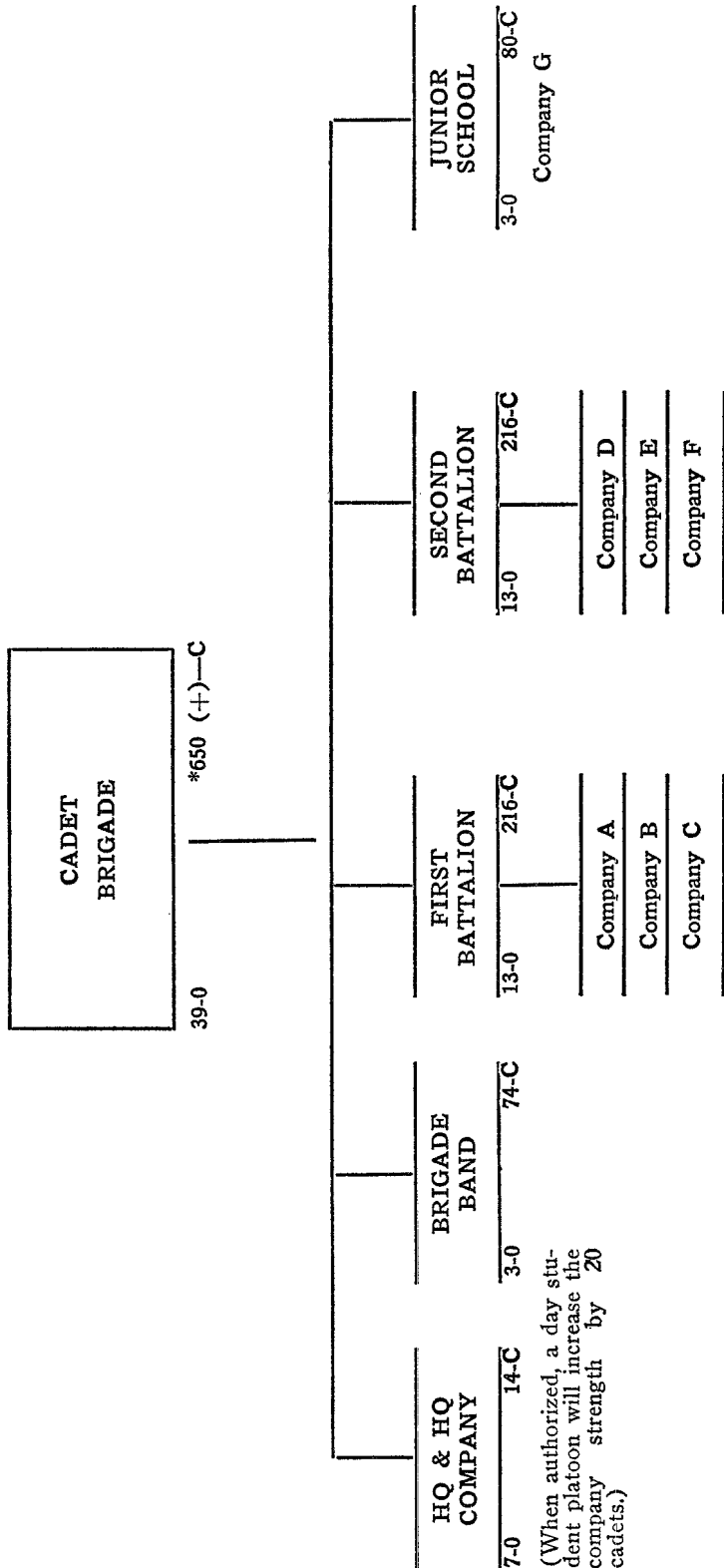

*Note: Strength will vary depending upon enrollment.

Figure 6

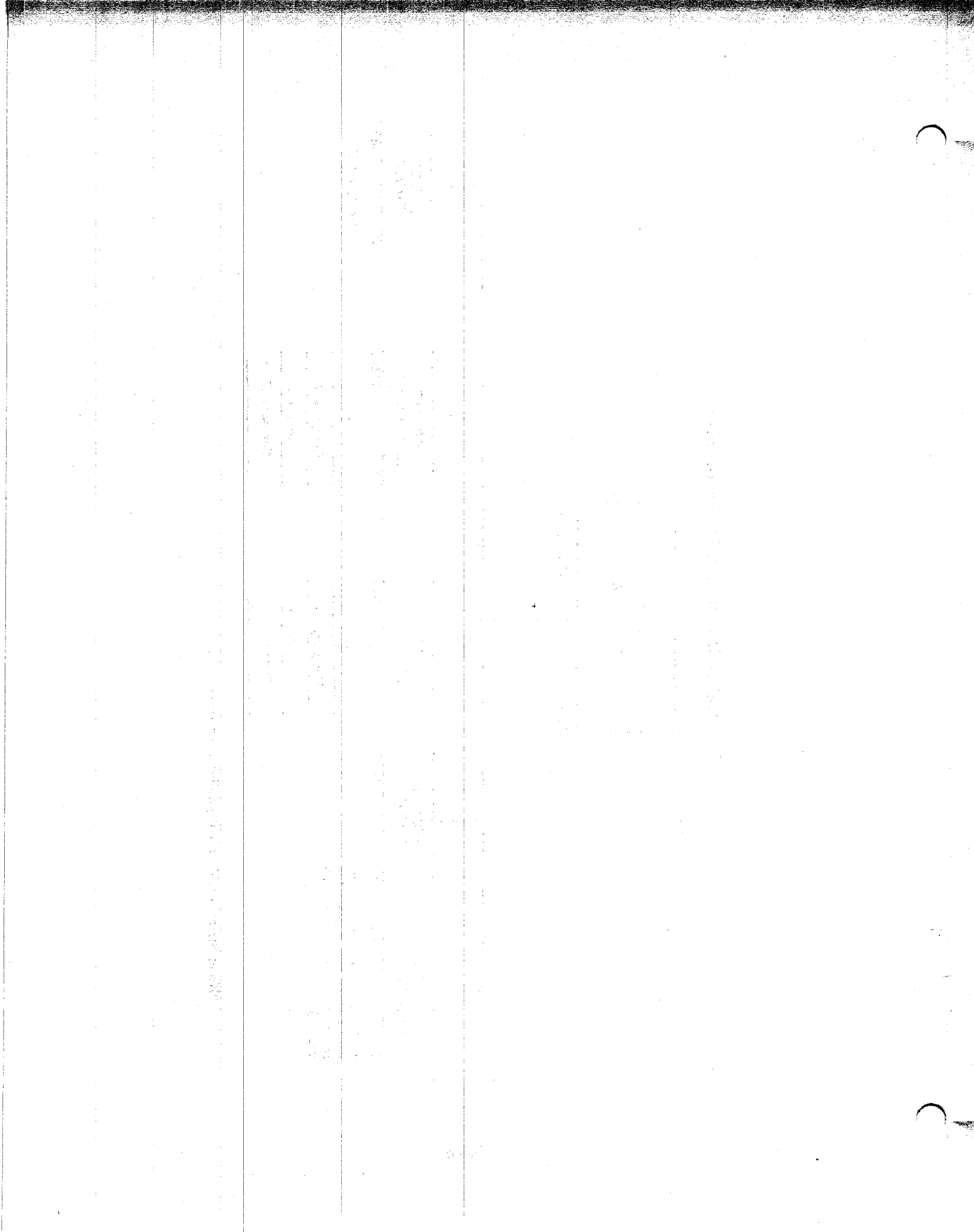

SECTION 25. PERSONAL PROPERTY

1. **Marking Property:** Cadets will clearly mark their clothing, caps, and other personal property for identification. A cadet's laundry stamp may be used for this purpose.
2. **Property Responsibility:** Each cadet is responsible for his personal possessions and should properly care for them accordingly. Articles of unusual value or sums of money will be deposited temporarily with the Treasurer or Commandant. The Academy cannot be responsible otherwise.
3. **Lost and Found:** Lost articles will be reported at once to the Commandant with description, and when possible, with time and place of loss. Items found will be at once turned in to the Commandant with pertinent information. Possession of an article reported lost, or one found and unreported, is a serious offense.
4. **Civilian Clothing and Trunks:** All cadet trunks and hand baggage will be locked in trunk rooms with proper identification tags on each piece. No outer civilian clothing of any kind will be kept at the Academy or in the city of Staunton. Items of civilian clothing will be sent home as directed. Having civilian clothing in one's possession is a serious offense.
5. **Clothing Repairs and Replacement:** In order to present a neat appearance at all times, each cadet should keep uniforms and clothing in proper repair, cleaned, pressed, and properly fitted and laundered at all times. Disreputable clothing must be repaired or discarded. It may not be worn.

THE HISTORY OF THE UNITED STATES

The history of the United States is a story of growth and change. It begins with the first settlers who came to the continent in search of a better life. They found a land of opportunity, but also a land of conflict. The struggle for independence was a long and hard one, but in the end, the people of the United States won their freedom and established a new nation.

The early years of the United States were marked by a period of rapid expansion. The country grew from a small collection of colonies to a vast continent. This growth was driven by a desire for land and a belief in the American dream. The westward movement of the population led to the discovery of gold and other resources, which further fueled the expansion.

As the United States grew, it also became a more diverse nation. People from many different backgrounds and cultures came to the United States, and they brought with them their own traditions and customs. This diversity has been one of the strengths of the United States, and it has helped to create a rich and varied culture.

The history of the United States is a story of progress and achievement. It is a story of a nation that has overcome many challenges and has emerged as one of the most powerful and influential countries in the world. The United States has made many contributions to the world, and its history is a testament to the power of the human spirit.

SECTION 26. PROMOTION POLICY

1. Selection:

a. Cadet Officers and Noncommissioned Officers are selected to command, direct, and control the Corps of Cadets as a unit. As such they exercise the authority commensurate with their grade under the guidance of the SAI with the advice of the school authorities, (Commandant, Headmaster, and Superintendent) on the basis of demonstrated ability and attention to duty. Initial appointments and reductions are made from time to time by the SAI at any time that a cadet officer or noncommissioned officer demonstrates his unfitness through inefficiency. The Commandant of Cadets handles cases of misconduct.

b. Students are considered for promotion on the basis of the number of years completed at the Academy and selected on the basis of demonstrated leadership ability, good conduct, and academic achievement.

c. Students returning to school will not normally return with a lesser rank than that held at the previous school term.

d. A cadet will not normally be promoted during his first year at the Academy. However, he may be promoted under the following conditions:

(1) Certain designated outstanding new cadets may be given temporary rank as acting non-commissioned officers in order to fill vacancies in their units created by a shortage of qualified noncommissioned officers with the necessary time in grade. Such acting NCO's have the authority and privileges of the temporary grade they hold, except that acting NCO's are not authorized to wear the insignia of that grade.

(2) New cadets who have demonstrated superior conduct, excellence in academics, and excellence in Military Schools Training may be promoted up to the rank of Sergeant after the first semester of the school year.

(3) If a new cadet has had prior ROTC training, he may be promoted to a higher rank.

2. The following criteria is outlined as a guide for the election and promotion of cadet officers and noncommissioned officers:

a. Cadet Officers:

(1) Be a senior

(2) Be enrolled in Military Schools Training 3 or 4

(3) Have completed a minimum of 2 years at the Academy

b. Cadet First Sergeants, Master Sergeants and Sergeant First Class:

(1) Be a Senior or Junior

(2) Be enrolled in Military Schools Training 2, 3, or 4

(3) Have completed a minimum of one year at the Academy

c. Cadet Staff Sergeants :

- (1) Be at least a Sophomore
- (2) Enrolled in Military Schools Training 2, 3, or 4
- (3) Have completed a minimum of $\frac{1}{2}$ year at the Academy

d. Cadet Sergeant or Corporal :

- (1) Must have completed the first semester of Military Schools Training 1.
- (2) Have completed a minimum of one year at the Academy (except as noted in para 1d above)

3. Recommendation procedure for promotion :

a. Recommendations for promotions are submitted by the Cadet Commander through their Tactical Officers to the SAI.

b. In May of each school year, the Cadet Brigade Commander with the advice of the Battalion Commanders will submit to the SAI recommendations for key personnel, for the following academic year. Cadet company commanders will submit to their company Tactical Officers similar recommendations for vacancies in their units. (The recommendations must be kept confidential by all concerned).

4. Announcement of Rank :

a. During the school year, promotion announcements will be made in Cadet Special Orders as the need arises.

b. The appointment of Brigade and Battalion Commanders for the next school year will normally be made during graduation week.

c. Key cadet officers and NCO's will be advised in August of their appointment in the cadet corps.

d. Other ranks will be announced when school opens.

SECTION 27. SALUTES AND COMPLIMENTS

1. Courtesy in the military is indispensable to discipline. Cadets will salute all personnel of the Army, Air Force, Navy Marine Corps, and SMA faculty not only on the Academy ground but in town as well.

2. In all matters of military courtesy, salutes and compliments, cadets will comply with regulations pertaining to Military Courtesy as published in appropriate US Army manuals and taught here at the Academy. Cadets will be punctilious in rendering and returning salutes.

3. On all official occasions and duties, cadets will exchange salutes when one addresses another and again when they separate.

4. Courtesies to Academy Officers:

a. A cadet wishing to speak to an officer shall approach, salute, and say, "Sir, Cadet, **Name**, requests permission to speak to Rank, **Name**". When reporting to an officer in his office, a cadet will remove his headress outside, unless under arms, knock, and enter when told to do so. Upon entering, he marches two paces from the front of the Officer's desk, salutes, and says, "Sir, Cadet, Rank, **Name**, reports as ordered", or "Sir, Cadet, Rank, **Name**, would like to ask a question", or "Sir, Cadet, Rank, **Name**, requests permission to answer a stick". Salutes will be held until acknowledge acceptance of the report by returning the salute. When the business is completed, the cadet salutes; when the salute has been completed, executes an about face and withdraws, closing the door if it was closed upon entering. If the cadet is under arms, he will NOT remove his headgear, and instead of the hand salute, he will render the proper rifle salute.

b. When asked his rifle number a cadet will reply by using the following form: "Sir, my rifle number is ———, Sir". In formation, the following form: "Sir, my name is Cadet, Rank, **Name**", or "Sir, that press belongs to Cadet, Rank, **Name**".

5. Courtesies Among Cadets:

a. In official communications between cadets the last name shall be used and the communication shall be made in a dignified manner.

b. Cadets shall make use of the word "Sir" in answering official questions asked by cadet commissioned officers or cadets acting as such.

c. New cadets will stand at attention when cadet officers enter their rooms.



SECTION 28. SCHOOL AND U.S. GOVERNMENT PROPERTY

1. Arms and equipment issued from the Armory are either the property of SMA or the United States Government. To carry away, destroy, or dispose of this property is a serious offense.

2. Each cadet shall receipt for articles drawn, keep them in serviceable condition, and turn them in to the Armory before leaving school for a period of three or more days.

3. No cadet shall borrow, exchange, or transfer any rifle or article of military equipment at any time, or for any purpose, without permission of the SAI.

4. Breakages and damages of any kind to school property will be investigated and necessary cost of repairs or replacement shall be charged to the responsible person.

5. Any intentional damage to property, or any damage caused by gross carelessness, will result in severe punishment of the responsible person and the requiring of said person to pay for damage.

6. Arms and equipment will be kept in the racks provided and shall not be removed therefrom at any time except for cleaning and for drill or other military formations under arms.

7. Scraping, filing, cutting, or otherwise altering a rifle or taking it apart is positively forbidden except as specifically authorized by the SAI or one of his assistants.

8. Each cadet will be held responsible for the cleanliness and good order of his arms and equipment.

9. The loss of any arms or equipment, or any part thereof, shall be reported at once to the SAI, by the cadet himself, and also by any officer or cadet who finds lost articles.

10. Company First Sergeants are responsible to turn in equipment belonging to cadets who go AWOL or to the hospital for prolonged periods.



SECTION 29. SOCIAL FUNCTIONS, FRATERNITIES AND SOCIETIES

1. All dances and similar social functions at the Academy shall end at a previously stated time by the authority allowing the dance.
2. Cadets will be particularly observant of the usual social amenities upon arrival and departure, will not make themselves conspicuous by their style of dancing and will not make themselves objectionable by excessive "cutting-in" upon dancers or attempting to dance without proper knowledge or instruction.
3. Those attending social functions will sign out and in "On Honor" both with the barracks supervisor and with the Sergeant of the Guard in person, and in so doing, indicate that they are not taking advantage of the opportunity to go elsewhere than to the specified function.
4. Cadets attending a dance at the Academy without dates are allowed fifteen minutes from the end of the dance to report in. They are not allowed to leave "The Hill".
5. The Senior Class is allowed to organize as such, elect and install officers, and hold meetings for the purpose of furthering the class activities.
 - a. The Senior Class shall be composed of the following groups of cadets: candidates for graduation, post graduates, and those with three years of high school and eleven units.
 - b. Organization of the class is as follows:
 - (1) A Faculty advisor appointed by the Administration of the Academy.
 - (2) Class officers elected from the membership of the class: president, vice-president, secretary, treasurer.
 - (3) The officers shall be elected in the spring of the year prior to graduation.
 - c. Special senior privileges will be announced by the Commandant as appropriate.
 - d. Senior Class activities will be organized and scheduled by the class, class officers, and faculty advisor with the approval of the school administration.
7. No society may be organized for any purpose by cadets except by authority of the Superintendent, based upon written application accompanied by a full statement of its purpose, its proposed organization and its proposed procedure.



SECTION 30. STUDY HALL REGULATIONS

1. All cadets (except seniors, post-graduates, and honor students) will attend day study hall at all periods they do not have a class unless specifically excused by the Headmaster.
 - a. No cadet is considered a senior, post graduate, or honor student unless his name appears on the official lists issued by the Headmaster's Office.
3. Uniform for day study hall will be the uniform for class.
4. There will be no talking or disorder of any kind upon entrance to the study hall; each cadet will proceed immediately to his seat and stay there and speak to no one. This applies to day study hall and to both periods of the night study hall.
5. Cadets not in their seats when the bell sounds for the beginning of each class or at 1915 and 2030 will be reported late.
6. Cadets who should attend day study hall and do not will be marked absent for each day they should have been in day study hall and did not attend.
7. Cadets may be excused day study hall to go to the library or administrative offices by presenting the proper request to the supervisor of the study hall.
8. No cadet may leave his seat to see the Officer in Charge of the study hall except by raising his hand and securing permission.
9. No cadet will be given permission to move from his seat to ask questions of another cadet or to borrow anything from anybody. Request will not be made for such permission.
10. Night study hall will normally be held from 1915 to 2140 hours on Monday, Tuesday, Wednesday, and Thursday nights.
11. Cadets are assigned to night study hall at the end of each marking period. Assignments are based on the recommendations of teachers, barracks duty officers, the Headmaster, and the requests of parents.
12. Cadets are assigned to night study hall for one or two CQ's at the discretion of the teacher concerned and the Headmaster.
13. Cadets may volunteer to attend night study hall. Volunteers may remove themselves from night study hall.
14. Cadets may be removed from night study hall by bringing the Headmaster a note from the teacher who recommended his attendance at night study hall.
15. Call to quarters at 1910 will serve as first call to night study hall for those to attend. Such cadets will perform their regular police duties in rooms and barracks prior to 1910.
16. There will be an intermission between the sessions of night study hall between 2020 and 2030 hours.
17. There will be no talking or wandering about in the study hall during intermission; cadets who remain in the hall must stay in their own seats.

18. Uniform for night study hall will be the uniform for class. Ties may be removed while in study hall.

19. Permission will not be granted to leave the night study hall except in case of illness, or with the permission of the study hall supervisor.

20. No study hall is ever dismissed by any bugle call or bell, only by order of the Officer in Charge of the Hall.

21. Upon dismissal, cadets will leave the Hall in an orderly manner and without talking.

22. Confinement Study Halls will be scheduled as needed.

23. The purpose of confinement study hall is to provide opportunity for cadet to make up work not handed in or properly done in class, to study work not thoroughly learned, and to emphasize the fact that work must be done on time and in the prescribed manner.

24. Confinement study hall will take precedence over special leave, athletic team practice, and beat squad (until cadet has 10 or more hours).

25. Cadets may be excused from confinement study hall only by the teacher assigning the cadet to the study hall or by the Headmaster (in special cases only).

26. Cadets excused from attending confinement study hall must turn in the work assigned for the study hall to the Headmaster's Office by 0800 the following morning.

27. Uniform for confinement study hall will be Summer or Winter "A" depending on the season.

SECTION 31. SUPPLY ROOM

1. Within the limits of the deposits made for this purpose, all articles of uniform and equipment, books, stationery, drawing materials, athletic items, and miscellaneous articles supplied by the Academy, shall be obtained from the Supply Room. When the deposit of books, stationery, uniforms and uniform equipment for any cadet has been used, no further items shall be issued to the cadet without written approval from the Treasurer's Office.
2. SMA military-type property will be issued by direction of the SAI.
3. Athletic goods and miscellaneous articles not a necessary part of academic or military equipment are obtained upon requisition approval by the Treasurer.
4. Cadets shall sign receipts for all articles or supplies purchased from the Supply Room.
5. The sale or giving away of books or other articles purchased from the Supply Room, or purchased elsewhere or brought from home, is forbidden unless it be done by authority of the parent or guardian and with the approval of the Treasurer.
6. Cadets will enter the Supply Room dressed in a complete uniform.

SECTION 32. WEARING OF THE UNIFORM

1. **General:** Wearing of the Cadet Uniform is a distinct privilege. To wear the uniform improperly or in a slovenly manner at any time is an act of disrespect to SMA. Regulations carefully prescribe the correct manner of wearing the uniform and these regulations must be strictly obeyed. Each cadet is required to have three name tags in good condition at all times. Name tags are habitually worn as prescribed on the "C" coat, gray shirt, and "D" coat.

2. a. **Types of uniform worn by SMA cadets are enumerated in Appendix I.**

b. The uniform when worn off the Academy grounds will always be worn properly, ie., blouses will be buttoned at all times and hats will be placed properly on the head. The practice of removing or unbuttoning the blouse in public or in walking around with an unbuttoned outer garment, will not be tolerated.

c. The white shirt is **never** worn except under the "C" coat or with white ducks without "C" coat when so prescribed.

d. When leaving the barracks for any reason, a complete uniform will be worn to include a tie and regulation shoes. The uniform to be worn during CQ is prescribed in Section 3.

e. Athletic sweater with appropriate letter may be worn on campus to classes and 2nd mess during school days. It may be worn on the grounds at any time other than in formation. It is **always** worn with a gray shirt. On occasion, this sweater may be worn by athletic teams leaving the grounds. The sweater with "S" is only to be worn by cadets who have earned the privilege in varsity or junior varsity sports.

3. **Insignia:**

a. Branch and School Insignia will be worn as shown in Figure 7.

b. Officer insignia of rank will be worn on the "C" coat as shown in Figure 8.

c. Insignia of rank and branch for officers will be worn on the grey shirts shown in Figure 9.

d. Insignia of rank for officers will be worn on the overseas cap as shown in Figure 10.

e. When wearing the "C" coat, officers will not wear insignia on the shirt; insignia will be worn on the shirt when the "D" coat is worn, or in Uniform "A".

4. **Decoration, Badges, Etc.**

a. Cadets are permitted to wear **ONLY** those decorations awarded by Staunton Military Academy, such as marksmanship medals, military medals, etc., or those medals won while a member of an SMA team in competitive events. National Rifle Association awards may be worn. Medals from the Boy Scouts, or other schools or camps are not authorized for wear on the SMA uniform.

b. In wearing badges, ribbons and other decorations, the following regulations apply:

(1) Authorized cadet medals normally will not be worn on the "C" uniform when ribbons and badges are being worn.

(2) Ribbons and badges will normally be worn on cadet "C" uniform except as subsequently indicated below or as directed.

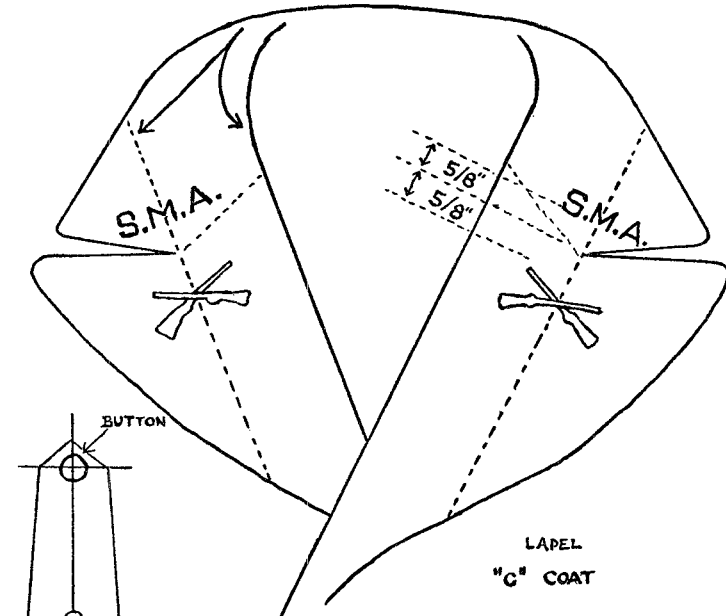

Figure 7

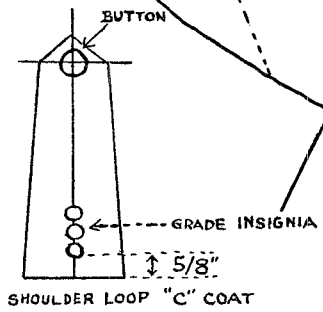

Figure 8

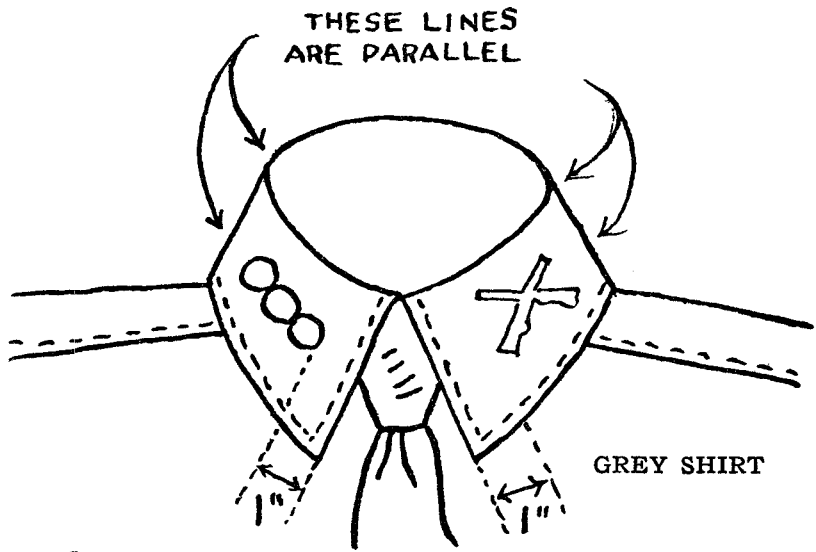

Figure 9

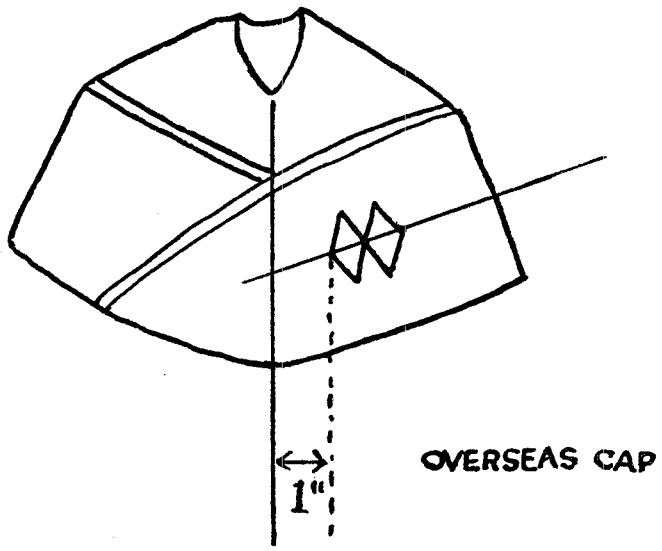

Figure 10

(3) Medals will be worn for formal occasions such as: Dances, parades, formal inspections. They may be worn on Sundays when the "C" uniform is prescribed.

c. Precedence in wearing ribbons will be: Superior Military School Cadet, Superior Junior Cadet Ribbon, Association of US Army Ribbon, Academic, Conduct Ribbon (Superintendent, Headmaster, Commandant, and Military Ribbons) and athletic ribbons.

d. Ribbons will be worn above the left breast pocket (3 to a row) with the highest ranking ribbon on the top row to the wearer's right. Badges will be worn on the pocket flap. (Figure 11)

e. Precedence among medals will be: Kable Legion of Honor, Citizenship Medal, Army and Navy Legion of Valor Bronze Cross, Association of US Army Medal, Superior Military Schools Cadet Medal, Superior Junior Cadet Medal, Association of Military Schools and Colleges Medal, Academic Medals and others.

f. Medals will be worn in overlapping rows above the left breast pocket. The highest ranking medal will be on top and to the wearer's right.

g. The Honor Committee star will be worn $\frac{1}{8}$ inch above and centered over the right breast pocket. The name tag will be worn $\frac{1}{8}$ inch below the top of pocket. (Figure 12)

h. The academic pins will be worn $\frac{1}{8}$ inch above and centered over ribbons on the left breast pocket.

i. Cadets who were members of the selected Honor Company for preceding school year may wear the Honor Company pin on the center of the right "C" coat pocket. (Figure 12)

j. Band lyre will be worn centered, left sleeve, 6 inches above the edge of sleeve.

k. The Howie Rifles distinctive shoulder patch is worn on the right sleeve of the "C" coat and overcoat.

5. Military Training Service Bars:

a. Regulations prescribe that one silver bar may be worn on the right sleeve of the coat after successful completion of one year of Military Training.

b. Example: If a cadet has successfully completed MST I, MST II, and MST III, and is currently taking MST IV, he is entitled to wear only 3 bars.

6. SMA Service Stripes:

a. Regulations prescribe that one small black stripe may be worn on the sleeve above the broad black band for each year of attendance at the Academy.

b. Example: If a cadet entered the Academy in his Freshman year, attended that year, both Sophomore and Junior years, and is now a Senior, he is entitled to wear 3 stripes.

c. Attendance at the Junior School is credited in connection with this regulation.

7. SMA Senior Cord:

a. All bona-fide seniors, as determined by the Headmaster, are entitled to wear the senior cord.

b. Only the regulation senior cord will be worn.

8. The appropriate athletic or exercise uniform may be worn while participating in any sport, in going to and from the field or gymnasium and under circumstances where the changing to correct uniform would require cadets to return to barracks from the athletic field to change uniform. Example: Members of the track squad will be permitted to watch baseball games in the track uniform, etc. Each cadet is expected to have a complete set of SMA sweat clothes. The practice of wearing sweat clothes and/or athletic clothes which are not SMA or which are torn or otherwise unserviceable will not be permitted. Stocking caps or other than SMA uniform headgear are likewise not authorized. Only SMA athletic shorts may be worn as an outer garment when shorts are worn.

9. Galoshes or rubbers may be worn during inclement weather.

10. Whenever the black tie is worn without blouse or jacket, it will be neatly knotted at the throat (not loose), and the ends will be tucked in between the second and third buttons of the shirt.

11. The cap is a part of the uniform and will be worn at all times when outside of buildings. Except when under arms, caps will be taken off or put on at the door of the classroom, Mess Hall, etc., and will never be worn inside of a room or hallway.

12. Wearing civilian type belts at any time will not be permitted. The black web belt with brass buckle is the only belt to be worn under the "C" coat or with fatigue clothing.

13. The use of "spray on" type shoe polish is prohibited.

LEFT BREAST POCKET

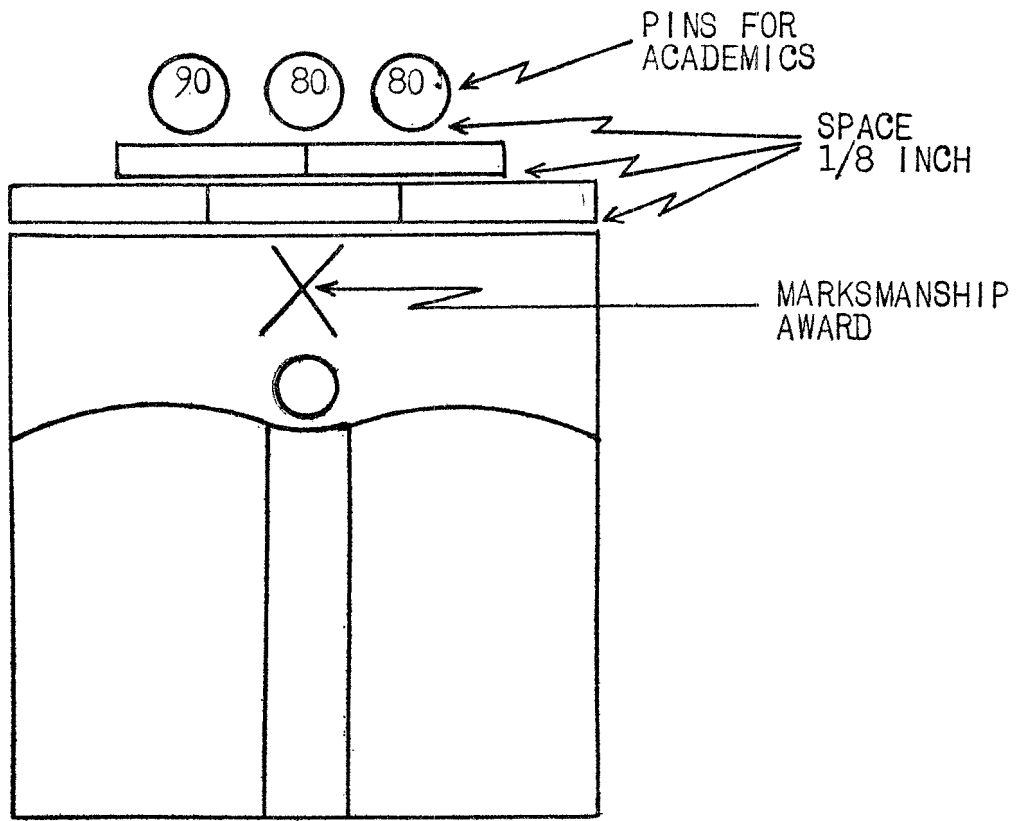

Figure 11

RIGHT BREAST POCKET

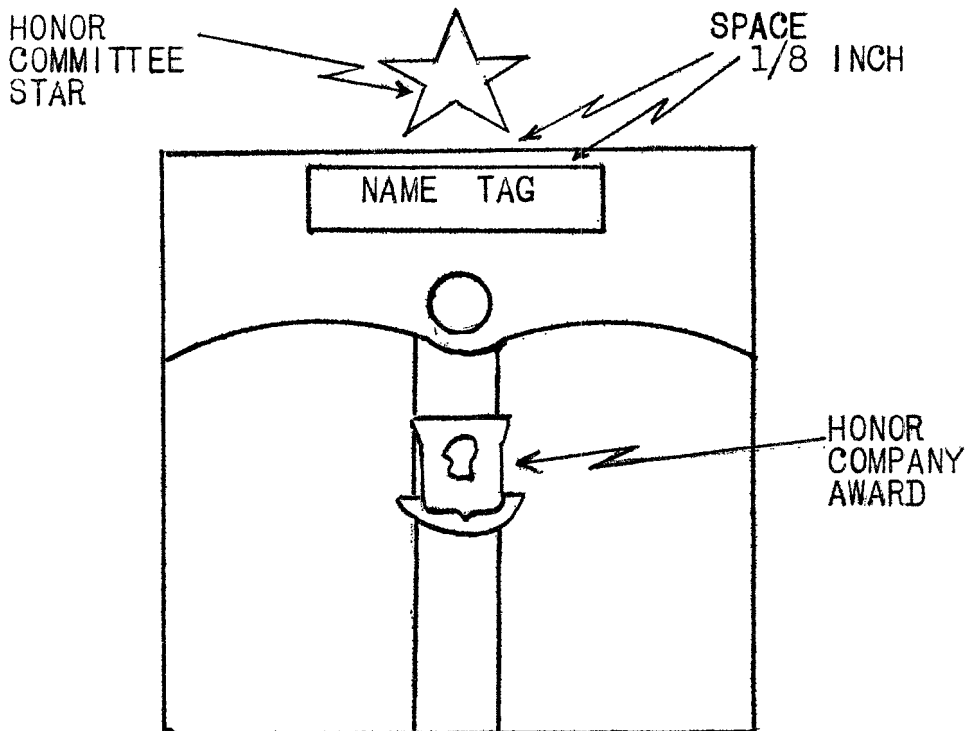
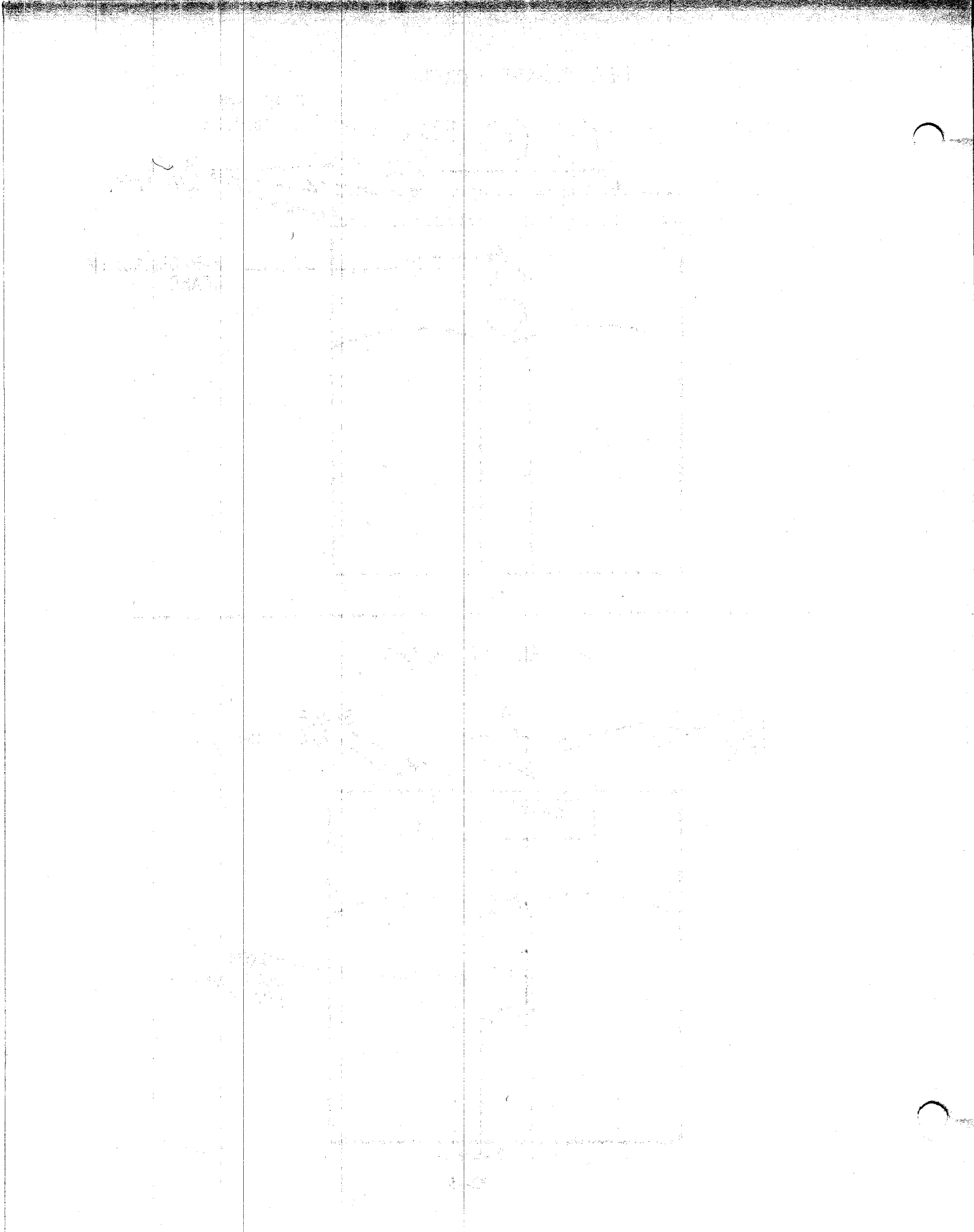

Figure 12



SECTION 33. MISCELLANEOUS

1. Cadets are prohibited from selling or attempting to sell to other cadets insurance, merchandise, or other articles, and from lending money to other cadets at interest. Cadets may, with the permission of the Commandant, assume paper routes on the school grounds.

2. The Cadet Store (Canteen) is operated for the benefit of the Corps of Cadets and will open daily at regularly prescribed hours. Cadets making purchases at the Cadet Store will not throw paper cups or containers of any kind in front of the Cadet Store or on the campus, but will place all refuse in the containers provided.

3. The Office of the Senior Army Instructor (SAI) publishes the Corps Training Schedule weekly. It is designated to keep cadets informed of what activities are planned for the current week. All company officers, the First Sergeants, and the Platoon Sergeants are issued one of these schedules. One copy is posted on the Military Department Bulletin Board in the hall of North Barracks. Cadets are held responsible for knowing the information contained therein.

4. Personal firearms, other weapons, ammunition, firecrackers, fireworks, or other explosives are not permitted at the Academy and will not be brought by or sent to any cadet. Under exceptional circumstances, cadets who are members of the rifle team may be given permission by the Superintendent to have a special rifle or shot gun and ammunition shipped to the Commandant of Cadets for the cadet's use. The firearm will be kept in the Armory. Illegal possession of firearms or lethal weapons is considered a serious breach of discipline.

5. Holidays will be granted at such times and according to such regulations as may be laid down in orders.

6. Morning fatigue, police inspection, and guard duty are performed on holidays the same as other days.

7. Any change of address of parents or guardians will be reported by a cadet to the Superintendent's office without delay.

8. Smoking is permitted only by those cadets having the written permit of parent or guardian. Such permits will be secured or renewed annually by October 1st and shown to the Commandant for approval and record. Smoking is permitted in cadet rooms and in the Cadet Store only. Smoking is not permitted at any place in the City of Staunton, except at class dinners, parties, or at other functions where smoking is approved by the Commandant.

9. **EXCUSED MARCHING:** Cadets excused marching, PT or carrying a rifle will comply with special instructions issued from the Commandant's office. They will habitually attend reveille, retreat and personal inspection with their company.

a. Cadets excused carrying a rifle will attend all formations to include parades.

b. Those with allergies which prohibit their attendance in activities on Kable or Echols Field will form in front of North Barracks with books when such activities are scheduled. Every effort will be made to place such a cadet on other duties such as guard during weekends when corps activities are planned for the drill field.

10. It will be considered a serious offense for any cadet to remove, write on, or otherwise deface any notices placed on any official bulletin board on the school grounds.

11. The telephone in the Guard Room is for official use and to receive incoming calls only. In this connection, the following regulations will apply: No cadet will be called to the telephone during the aca-

demic schedule, the study period, or Call to Quarters except to answer long distance calls, and then only on approval of the Officer in Charge.

12. The pay telephones in the Guard Room are for the general use of cadets and are subject to the following regulations:

a. The telephones may not be used during the academic periods — 0810-1410 hours, whether the cadet has a regular class or not; nor during study periods or Call to Quarters, nor after taps.

b. The pay telephones will not be used to order food from downtown for delivery to the Academy.

c. Emergency calls may be made from these telephones only with the approval of the Officer in Charge.

SUMMER UNIFORMS

Uniform Designation	Composition	Use
A*	Grey Shirt, Black Tie, Worsted Trousers, Belt, Black Socks, Black Shoes, Overseas Cap	General Duty Uniform on the Academy Grounds
B*	Same as Uniform "A" except Garrison Cap instead of Overseas Cap	General Leave Uniform
C**	White Shirt, Black Tie, White Ducks, Blouse, Black Socks, Black Shoes, Garrison Cap with White Cap cover	W/out Full Dress: may be prescribed in lieu of "B" for leave; Mandatory for leave when attending social functions W/Full Dress; Parades and Ceremonies
D*	Same as Uniform "A" plus "D" Coat	General Duty Uniform on the Academy Grounds for cool weather
E	Same as "A" less black tie and overseas cap	Optional for "A" during "C. Q." Not to be worn outside of barracks
F*	Same as Uniform "A" less black tie	Drill
G	White Shirt, Black Tie, White Ducks, Belt, Black Socks, Black Shoes, Garrison Cap with White Cap cover	In lieu of "B" or "C" when announced
T	Same as Uniform "A" less shirt and tie and with white "T" shirt.	Drill during hot weather
X	Fatigue uniform to include cap and drill boots.	Drill and fatigue details

* To include raincoat as announced.

** When announced "C", Full Dress" to include white belting, white gloves, and wrap, black box, breast plate if appropriate.
Notes: 1. When the raincoat is worn, the rain cap cover is worn also.

2. With the exception of Uniforms "C" and "G", the wearing of white cap covers is reserved to Officers, Master Sergeants and members of the Guard.
3. SMA athletic award sweater may be worn with the "A" or "B" uniform to classes or on the school grounds when not in formation.
4. The blue knit cap may be prescribed by athletic coaches for wear with sweat clothing.

WINTER UNIFORMS

Uniform Designation	Composition	Use
A*	Grey Shirt, Black Tie, Grey Straights, Belt, Black Shoes, Black Socks, Overseas Cap	General Duty Uniform on the Academy Grounds
B*	Grey Shirt, Black Tie, Grey Straights, "D" Coat, Black Socks, Black Shoes, Garrison Cap	Saturday Inspections; Leave, when authorized as a "C" substitute
C**	White Shirt, Black Tie, Grey Straights, Blouse, Black Socks, Black Shoes, Garrison Cap	W/out Full Dress: General Leave Uniform W/Full Dress: Parades and Ceremonies
D*	Same as Uniform "A" with "D" Coat	General Duty Uniform on the Academy Grounds for cool weather
E	Grey Shirt, Grey Straights, Belt, Black Socks, Black Shoes	Optional for "A" during "C. Q.". Not to be worn outside of barracks
X	Fatigue uniform to include cap and drill boots	Drill and fatigue details

* To include overcoat, raincoat, and/or grey gloves as announced.

** When announced "C, Full Dress" to include white belting, breast plate, white gloves, and when appropriate, black box if appropriate.

Notes: 1. When the raincoat is worn, the rain cap cover is worn also.

2. The wearing of white cap covers is reserved for Officers, Master Sergeants and members of the Guard.

3. The SMA athletic award sweater may be worn with the "A" or "B" uniforms to classes or on the school grounds when not in formation.

4. The blue scarf will always be worn with the overcoat and may be prescribed with either "B" or "D" uniform.

5. The blue knit cap may be worn with any uniform in lieu of the otherwise prescribed cap when authorized by the Commandant.